



HARDSCAPES USA

Grand American Cobble

A PAVER PRODUCT OF HARDSCAPES USA™



For more product information and project ideas online, please visit www.hardscapesusa.com.



Born out of ancient inspiration, Hardscapes USA Premier Paver Grand American Cobble has a rustic, natural textured surface as though cut from rough stone.

The oversized 12"x12" unit is available as a stand alone unit but is typically paired (above) with the three smaller square and rectangular American Cobble shapes.



HARDSCAPES USA™

Outdoor Living Defined & Refined

Visit www.hardscapesusa.com for project ideas and product information.

Grand American Cobble

Paver Size	70mm
Sq. ft. per cube.....	108
Pieces per cube.....	108
Weight per cube (approx.).....	3400 lbs

Dimensions:

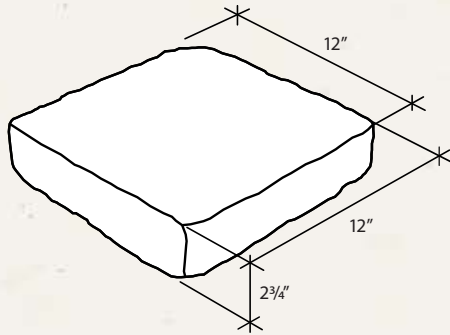

Styles: Visit www.hardscapesusa.com for product installation patterns.



Standard



Tumbled

Color Selections:

Standard colors are available using both gray and white cements, while an extensive collection of two and three color blends is available. To see the complete line of colors and blends produced in your market area, please visit our website at www.hardscapesusa.com.

Typical Installation:

1. Excavate subgrade material and compact the area which has been cleared. Then backfill with dense-graded aggregate (typically 4 to 6 inches for light vehicular and pedestrian traffic, increasing to 8 to 12 inches for heavy vehicular and industrial use) as directed by site engineer, architect, or landscape architect.
2. Place bedding course of sharp, normal-weight screening sand to a uniform depth of approximately 1-1/2 inches leveled to grade.
3. Install Hardscapes USA pavers on bedding course in pattern desired.
4. Where required, cut paving stones with an approved cutter to fit accurately, neatly and without damaged edges.
5. Tamp paving stones with mechanical vibrator uniformly level, true to grade and free of movement.
6. Fill voids in joints by sweeping in a fine, dry masonry sand.

The information contained herein is accurate to the best of our knowledge, but Hardscapes USA assumes no liability whatsoever for its accuracy or completeness. Final determination of suitability of any material is the sole responsibility of the user.



Product Composition:

Hardscapes USA pavers are made with zero-slump concrete, which is then hydraulically pressed while being subjected to extremely high frequency vibrations. This process results in Hardscapes USA pavers having a compressive strength of 8,000 psi or greater (ASTM C-936) and a moisture absorption of less than 5%.

About Hardscapes USA

Hardscapes USA is a manufacturer and distributor of a wide range of quality concrete products including pavers, retaining wall units, and patio products. They are produced and distributed throughout the Southeast and are used in residential, commercial, and industrial construction.

Hardscapes USA pavers are synonymous with distinctive paving applications and have earned a reputation for both quality and durability. Hardscapes USA pavers are well-suited for both the discriminating design application and the heavy-duty, functional project.